



臺北
表演藝術
中心

TAIPEI
PERFORMING ARTS CENTER

Grand Theatre

(GT)

Technical Information

Contents

Grand Theatre / GT	2
Load-in Gate and Scenery Shipping Path	3
Load-in Path.....	3
Load-in Entrance.....	4
Scenery Shipping Path	5
Stage Specifications.....	6
Stage Equipment.....	8
Lighting Specifications.....	17
Lighting Systems.....	17
Lighting Equipment List	18
Lighting Cable and Accessories	22
Dimmer circuits layout chart.....	25
House Light.....	29
Standard Light Plan.....	30
Audio Specification	31
Speaker System Dispose Chart	36
Panel Layout.....	38
Other Equipments & Dressing Room.....	39
Other Equipments	39
List of Dressing room.....	39

Grand Theatre / GT

- The stage floor of the GT is on the 4th floor

The stage platform contains the main stage, side stages and rear stage

Grand theatre have 1,460 seats, comprising orchestra pit 256 seats, 4&5F(Stalls) in total 584 seats, 6F(Circle) & terracing seat wall in total 587 seats, VIP balcony 16 seats, wheelchair seat 11 seats, think tank 6 seats.

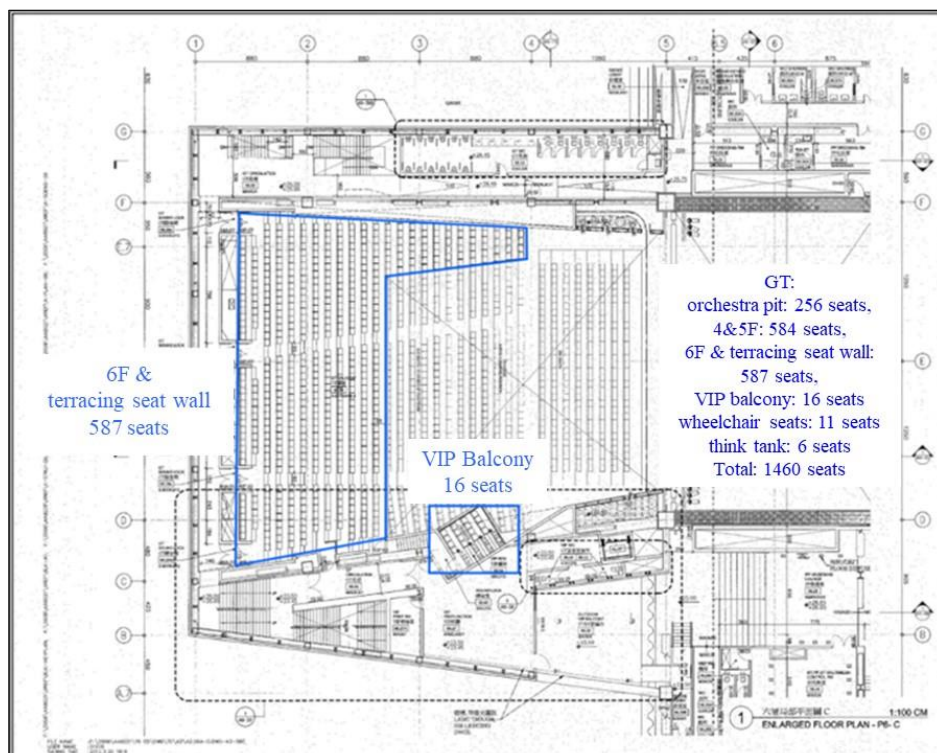
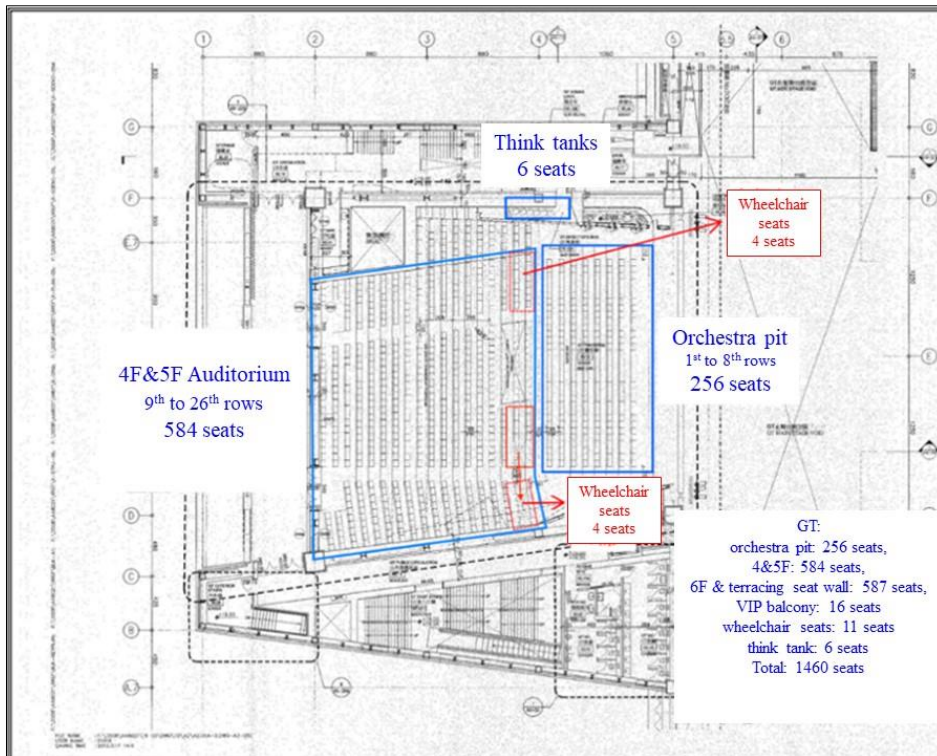

Load-in Gate and Scenery Shipping Path

Load-in Path

The load-in gate is located at the Chengde Road truck gate

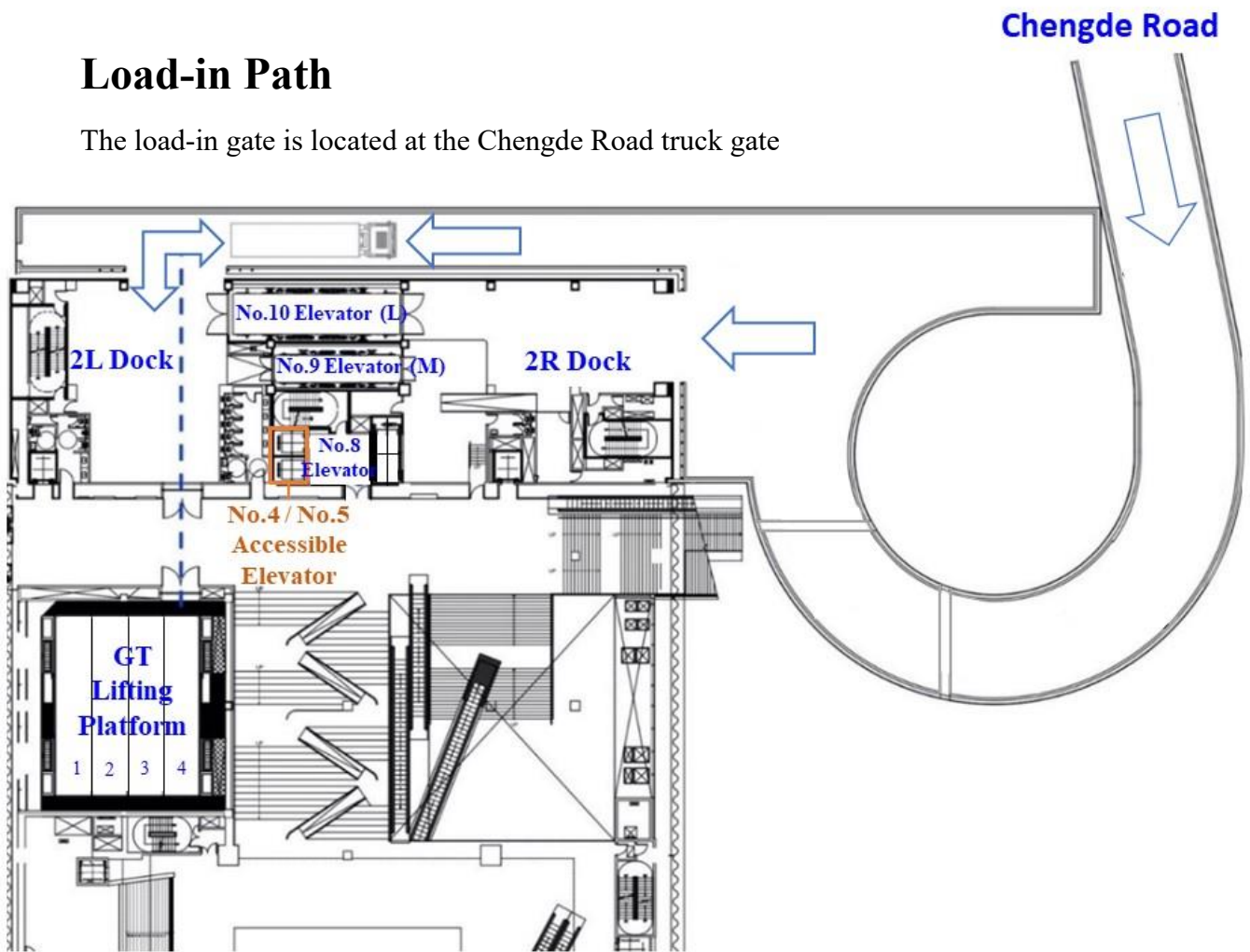

Dimension of lane : width 810 cm

Dimension of the load-in path of the GT: width 408 cm / Height 437 cm



Load-in area

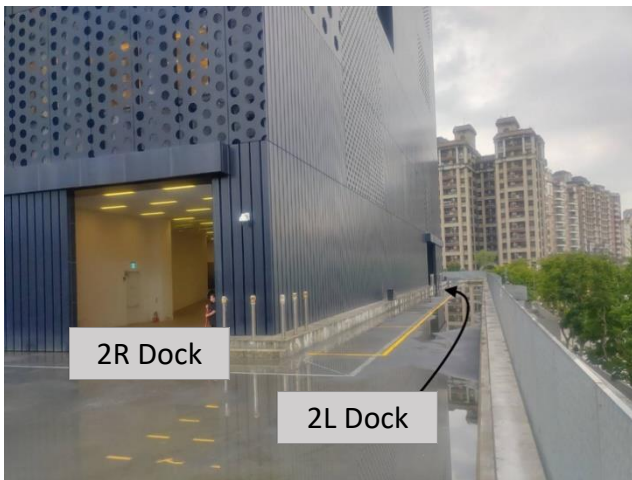

Load-in Entrance

Dimension of No. 10 Elevator entrance(4F) : **390** cm (W) × **340** cm (H)

Dimension of No. 9 Elevator entrance(4F) : **250** cm (W) × **290** cm (H)

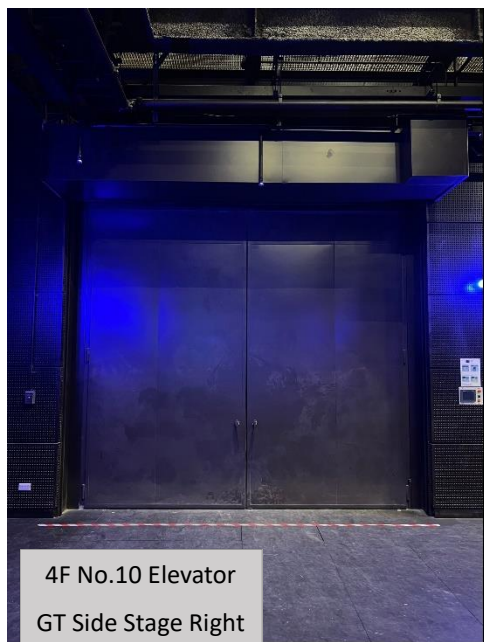

Scenery Shipping Path

Lifting Platform (only 3th 4th platform can descent to 2nd floor load-in dock)

Amount : 2

Dimension : 1500 cm (W) × 300 cm (D)

Maximum load : 9000 kg · 200 kg/m²

Floors to Reach : 2F : Single-Entrance/Driveway Level/load-in dock

4F : GT Stage Floor

Entrance : Gate 313 cm (W) x 295 cm (H)

stack door 190 cm (W) x 295 cm (H)

No. 10 Elevator

Dimension : 1405 cm (L) × 340 cm (W) × 400 cm (H)

Maximum load : 25000 kg

Floors to Reach : 2F : Double Entrance/Driveway Level

4F : Double Entrance/GT/BB Stage Floor

7F : Single Entrance/GP Stage Floor

No. 9 Elevator

Dimension : 1042 cm (L) × 210 cm (W) × 260 cm (H)

Maximum load : 8000 kg

Floors to Reach : 2F : Double Entrance / Driveway Level

3F : Single Entrance / Music Instrument Store room 200 (W) x 210 (H)/

GT Orchestra Pit 95 (W) x 200 (H)

4F : Double Entrance /GT/BB Stage Floor

5F : Single Entrance / Dressing Room

6F : Double Entrance / Dressing Room 147 (W) x 199 (H) /BB Grid/

GP Orchestra Pit

7F : Single Entrance /GP Stage Floor

No. 8 Elevator

Dimension : 400 cm (L) × 170 cm (W) × 230 cm (H)

Maximum load : 3000 kg

Floors to Reach : B1~12F

Stage Specifications

Stage Dimension

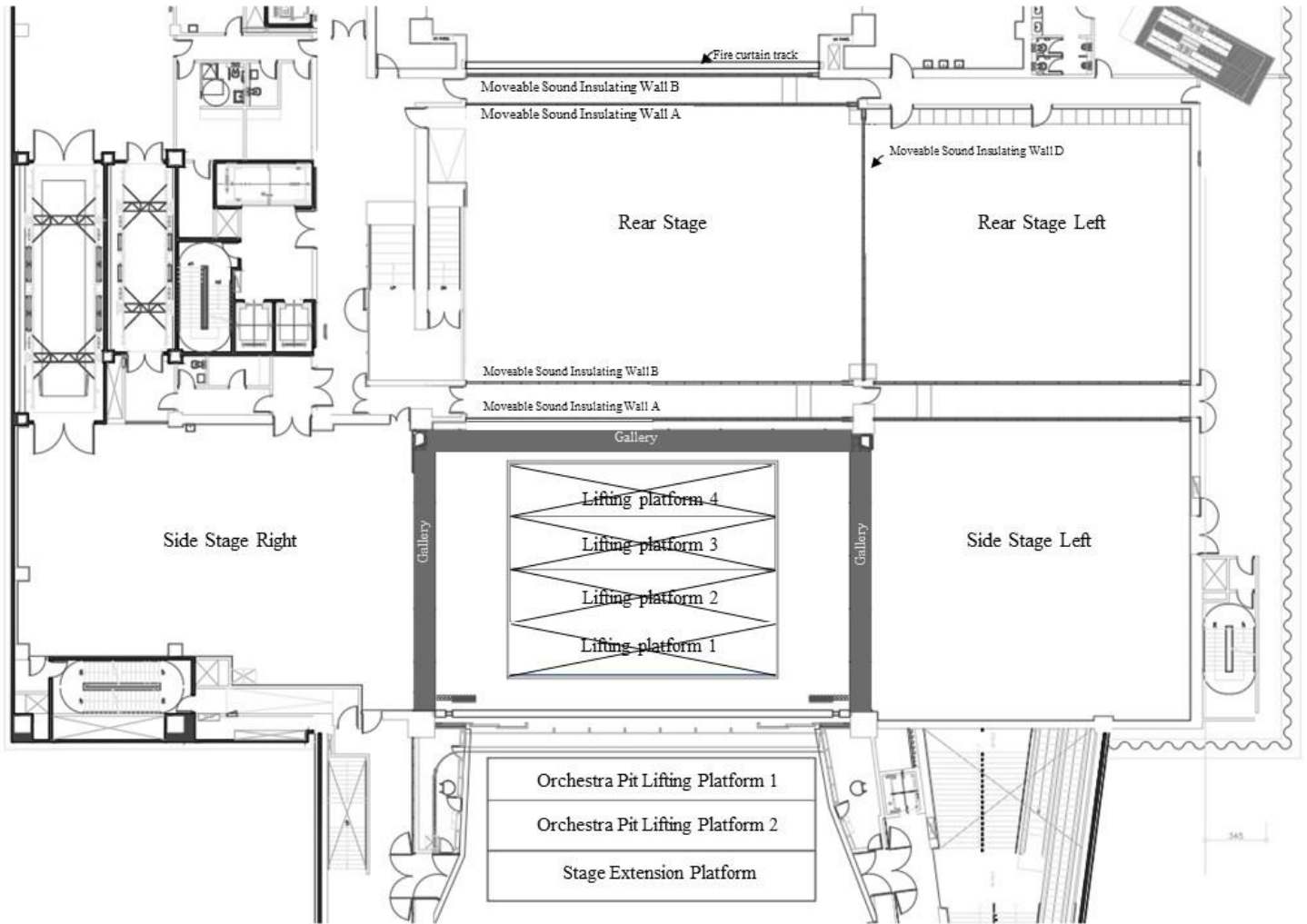

- i. Main Stage: Adjustable Proscenium : 1300 cm ~ 2000 cm
Proscenium to 1st Acoustic wall : 1706 cm
- ii. Side Stage Left : 1905 cm (W) × 1682 cm (D)
- iii. Side Stage Right : 2345 cm (W) × 1437.5 cm (D)
- iv. Cross Over : 2190 cm (W) × 190 cm (D)
- v. Rear Stage : 2190 cm (W) × 1535 cm (D)
- vi. Orchestra Pit Platform : (Comprising from 2 platforms which can be used independently)
 - Orchestra Pit Platform 1 : 1852 cm (W) × 240 cm (D)
 - Orchestra Pit Platform 2 : 1852 cm (W) × 285 cm (D)
 - Maximum load : Static Load : 500 kg/m² ; Dynamic Load : 200 kg/m²
- vii. Stage Extension Platform :
 - Dimension : 1852 cm (W) × 285 cm (D)
 - Maximum load : Static Load : 500 kg/m² ; Dynamic Load : 200 kg/ m²
- viii. Floor Surface : Black painted 3-ply plywood/45 mm, Loads Capacity : 750 kg/ m²

Stage Galleries

6th Floor Gallery : Height from Stage Floor : 980 cm · Stage L/R · Width : 100 cm

7th Floor Gallery : Height from Stage Floor : 1500 cm · Stage L/R/Up Stage ·
Width : 100 cm

8th Floor Gallery : Height from Stage Floor : 2000 cm · Stage L/R/Up Stage ·
Width : 100 cm

Grid (10F)

Height from Stage Floor : 2465 cm · Floorage : 2450 cm × 1675 cm

Loads Capacity : 150 kg/m²

Provide 8 Point Hoists (Please refer to the additional stage equipment)

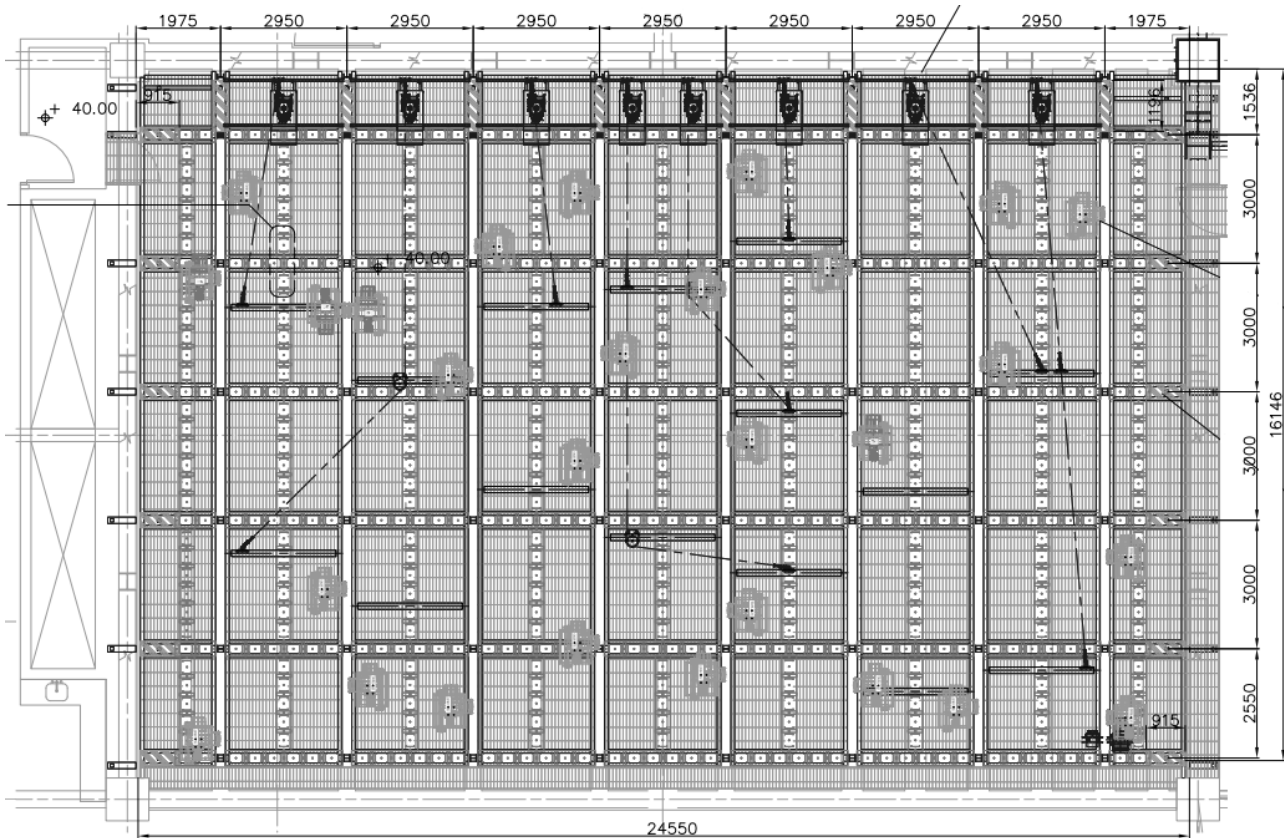

Stage Equipment

Lifting platform (**Not available currently**)

Amount : 4

Dimension : 1500 cm (L) × 300 cm (W)

Travel Distance : 1st / 2nd platform : 600 cm, (from stage floor) +300 ~ -300 cm

3th / 4th platform : 1570 cm, (from stage floor) +300 ~ -1270 cm

Loads Capacity : Maximum **9000** kg each

Dynamic Load : **200** kg/m²

Static Load : (upper level) **1000** kg/m² · (lower level) : **500** kg/m² °

Notes : When the lifting platform is 1M lowered than stage floor, the safety railing will be raised automatically

Orchestra Pit Lifting Platform

Amount : **2**

Not movable during performance

Orchestra Pit Lifting Platform 1

Dimension : **1850** cm (L) × **240** cm (W)

Travel Distance : Descent Maximum Distance **-450** cm

Ascent Maximum Distance is **Flush with Stage Floor**

Maximum load : Dynamic Load : **200** kg/m²

Static Load : **500** kg/m²

Orchestra Pit Lifting Platform 2

Dimension : **1850** cm (L) × **285** cm (W)

Travel Distance : Descent Maximum Distance **-400** cm

Ascent Maximum Distance is **Flush with Stage Floor**

Maximum load : Dynamic Load : **200** kg/m²

Static Load : **500** kg/m²

Stage Extension Platform

Dimension : 1850 cm (L) × 285 cm (W)

Travel Distance : Descent Maximum Distance -69 cm

Ascent Maximum Distance is **Flush with Stage Floor**

Maximum load : Dynamic Load : 200 kg/m²

Static Load : 500 kg/ m²

Adjustable Proscenium

3 pieces on Each Side · 6 pieces in total

Height : 1365 cm · Width : 165 cm (Each Piece)

Thickness : 35 cm (Up Stage) and 10 cm (Two pieces at down stage)

Opening : 1300 cm ~ 2000 cm

Operating : manual operation

Manual holder

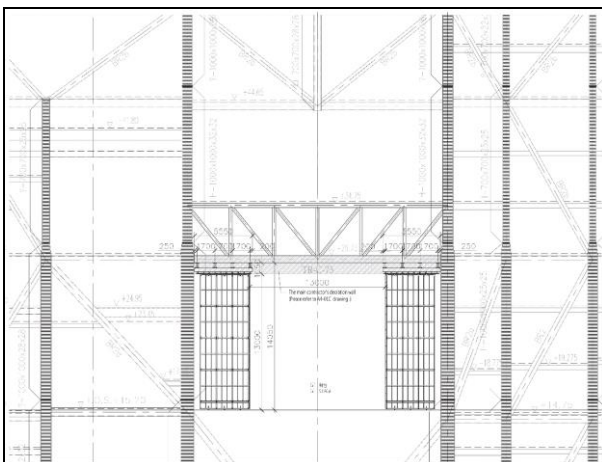
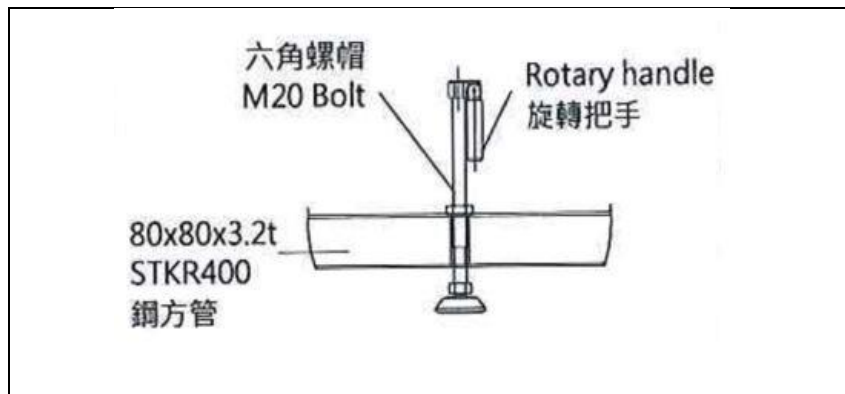

GT Proscenium Opening Minimum

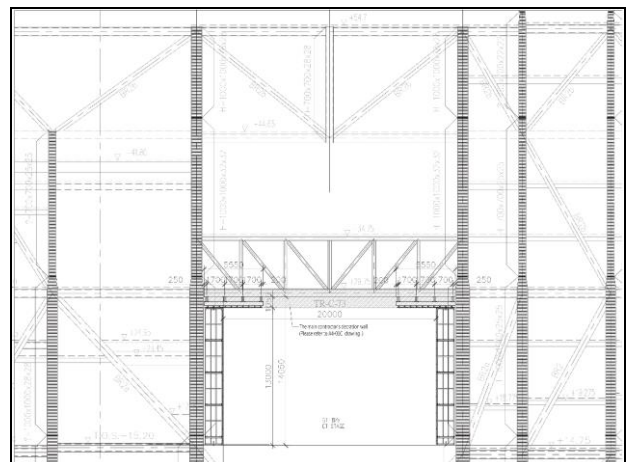

GT Proscenium Opening Maximum

Rigging System

i. Fly bar

- Main Stage

Type : Motorized variable speed fly bar

Amount : 57

(G57 is too close to the up stage gallery, for safety precautions, not available to use)

Bar spacing : 25 cm

Length : 2150 cm

(With 100 cm extension bar on both sides)

(over 80 cm will collide with gallery)

(over 30 cm will collide with side bar)

∅ Diameter : 4.83 cm

Loads Capacity : G01 : Travel House Curtain · permanent configuration

G02 : Lifting House Curtain

G02 to G57 : 500 kg · 100 kg/m

Extension bar : 50 kg

Travel Distance : (**From Stage floor**) +100 cm ~ +2300 cm

Speed : 0.012-1.2 m/s

- Side Bar

Type : Motorized fixed speed fly bar

Amonut : 4 · 2 on each side

Length : 600 cm (With 100 cm extension bar on both sides)

∅ Diameter : 4.83 cm

Loads Capacity : 400 kg · 100 kg/m · Extension bar : 50 kg

Travel Distance : (**From Stage floor**) +100 cm ~ +2300 cm

Speed : 0.5 m/s

- Up Stage below the gallery

Type : Motorized fixed speed fly bar

Amount : 2

Length : 2150 cm (With 100 cm extension bar on both sides)

∅ Diameter : 4.83 cm

Loads Capacity : 700 kg · 100 kg/m · Extension bar : 50 kg

Travel Distance : (**From Stage floor**) +100 cm ~ +1250 cm

Speed : 0.5 m/s

- **Front of House (Above Orchestra Pit)**

(Caused by obstruction from other equipments, Front G05 · G06 Not available recently)

Type : Motorized fixed speed fly bar

Amount : 6 (Only Front #01~ #04 in service)

Length : 1800 m

(With 100 cm extension bars on both sides)

∅ Diameter : 4.83 cm

Loads Capacity : 500 kg · 100 kg/m · Extension bar : 50 kg

Travel Distance : (**From Stage floor**) +100 cm ~ +1100 cm

Speed : 0.5 m/s

- ii. **Fire curtain**

2150 cm(W) × 1350 cm(H) · Thickness : 40 cm, Distance from Apron 60 cm

*When fire alarm is being triggered, fire Curtain will descent with alarm.

*Items that cannot be removed within 1 minute must not be placed under the fire curtain

- iii. **Lighting Bridge as Proscenium arch**

Dimension : 2000 cm (W) × 360 cm (H) × 100 cm (D)

Travel Distance : Measure with the header of the Lighting Bridge

(**From Stage floor**) + 800 cm ~ + 1150 cm

The hanging position is 2m higher than the lower edge of the lighting bridge header.

When the lighting bridge header is 8m height form the stage floor, the hanging position will be 10m height from the stage floor.

- iv. **G01 Travel House Curtain**

(As the house curtain is still under construction, only lifting function is available, and the Traveler function is Not available currently)

G01 permanent configuration, with curtain machine and track. Permanent configuration.

Material : Black Velour · Gerriets / Clivia 600

Dimension: 1000 cm (W) × 1200 cm (H)

Types of Opening : motorized, Flown and Traveler

Traveler Distance : 2200 cm · Overlap 100 cm

Traveler Speed : 0.1-1 m/s (variable speed)

Maximum Flown Distance : (**From Stage floor**) Fly bar: + 2150 cm, Bottom of Curtain: + 920 cm

Maximum Speed : 0.3 m/s

v. **G02 Lifting House Curtain**

G02 Black Curtain as Lifting House Curtain

Dimension : 2190 cm (W)×1190 cm (H)

vi. **Teaser**

In front of the Lighting Bridge · hard structure

2000 cm (W) × 460 cm (D) Thickness : 5 cm

Travel Distance : (**From Stage floor**) + 500 cm ~ + 950 cm

vii. **Rear Stage Truss**

4 Group of Truss named : US 、 DS 、 SR 、 SL, **Not movable during performance.**

Travel Distance : (**From Stage floor**) + 50 cm ~ + 1040 cm

Loads Capacity : US 、 DS 1600 kg

SR 、 SL 3200 kg

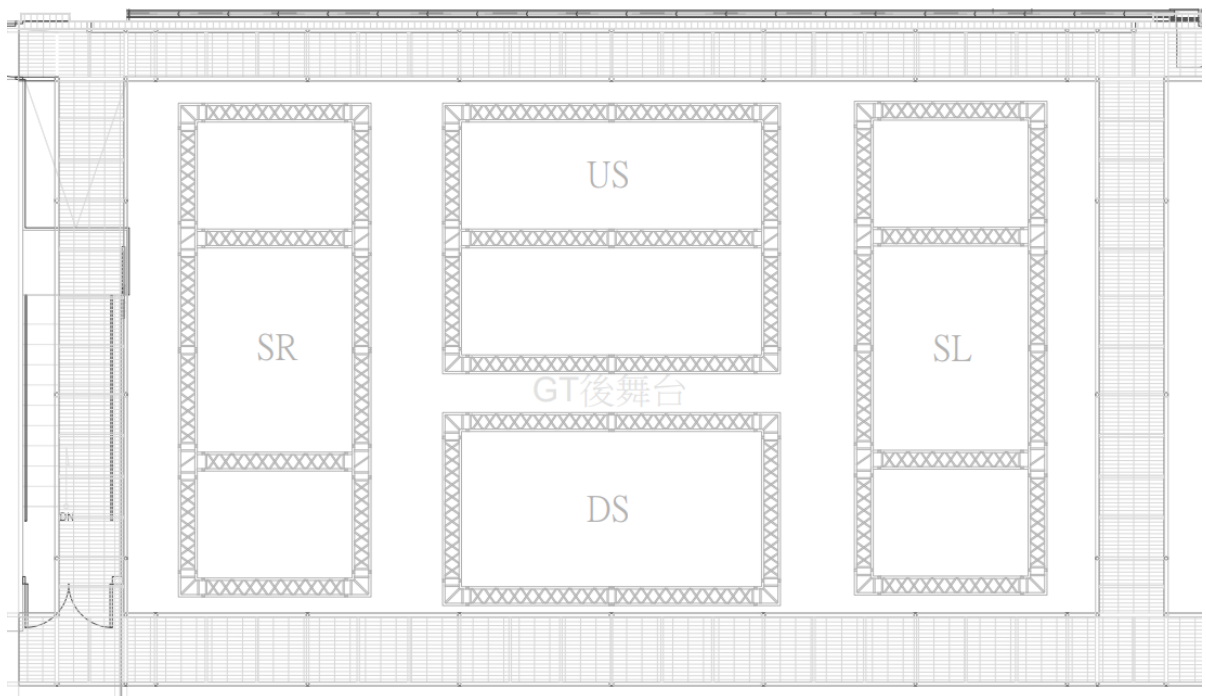

Hanging List

Fly Bar to Edge of Apron :

<i>No.</i>	To Apron (cm)	<i>No.</i>	To Apron (cm)	<i>No.</i>	To Apron (cm)
G01	316	G21	816	G41	1316
G02	341	G22	841	G42	1341
G03	366	G23	866	G43	1366
G04	391	G24	891	G44	1391
G05	416	G25	916	G45	1416
G06	441	G26	941	G46	1441
G07	466	G27	966	G47	1466
G08	491	G28	991	G48	1491
G09	516	G29	1016	G49	1516
G10	541	G30	1041	G50	1541
G11	566	G31	1066	G51	1566
G12	591	G32	1091	G52	1591
G13	616	G33	1116	G53	1616
G14	641	G34	1141	G54	1641
G15	666	G35	1166	G55	1666
G16	691	G36	1191	G56	1691
G17	716	G37	1216	G57	
G18	741	G38	1241		
G19	766	G39	1266		
G20	791	G40	1291		

Other Stage Equipment

i. Point Hoist :

- Fixed 4kN Variable speed point hoist
Amount : 8 **(Not available currently)**
Dimension : 200 cm×100 cm×80 cm
Loads Capacity : **400** kg
Travel Distance : **(From Stage floor)**+100 cm ~ +2500 cm
Speed : 0.012 ~ 1.2 m/s
Max acceleration : 0.6 m/s²
- Flexible 2.5kN Variable speed point hoist
Amount : 4
Dimension : 140 cm×100 cm×80 cm
Loads Capacity : **250** kg
Travel Distance : **(From Stage floor)**+100 cm ~ +2500 cm
Speed : 0.012 ~ 1.2 m/s
Max acceleration : 0.6 m/s²

ii. GIS Variable speed chain hoist **(Not available currently)**

Amount : 8
Loads Capacity : **500** kg
Speed : 0.02 ~ 0.3 m/min

iii. **List of Drapery :**

No.	Item	Size(m)	Color/Material	Amount	Note
1	Leg	450 cm (W) × 1200 cm (H)	Black/Velour	8 pairs	
2	Border	2200 cm (W) × 400 cm (H)	Black/Velour	8	
3	Back Drop	1100 cm (W) x 1200 cm (H)	Black/Velour	2	
4	Gauze Curtain	2000 cm (W) × 1000 cm (H)	Gerriets Black 6 point sharktooth Falstaff	1	chargeable items
5	Gauze Curtain	2000 cm (W) × 1000 cm (H)	Gerriets White Vision Gauze PARSIFAL	1	chargeable items
6	Rear Projection Screen	1800 cm (W) × 1100 cm (H)	Gerriets GmbH Black / PVC SHOWR 2.2 anthracite	1	chargeable items
7	Rear Projection Screen	2100 cm (W) × 1200 cm (H)	Gerriets GmbH Creamy White / PVC Prospekt OPERA Creamy white	1	chargeable items
8	Rear Projection Screen	2000 cm (W) × 1000 cm (H)	Gerriets GmbH Creamy White / PVC Prospekt OPERA Creamy white	1	chargeable items
9	Rear Projection Screen	2100 cm (W) × 1200 cm (H)	Gerriets GmbH Grey / PVC Prospekt STUDIO 200 gn	1	chargeable items
10	Rear Projection Screen	2000 cm (W) × 1000 cm (H)	Gerriets GmbH Grey / PVC Prospekt STUDIO 200 gn	1	chargeable items
11	Rear Projection Screen	1800 cm (W) × 1100 cm (H)	Gerriets GmbH Creamy White / PVC Prospekt EVEN white	3	chargeable items

iv. **Other Stage Accessories**

No	Item	Size	Amount	Note
1	Aluminum Ladder	180cm	2	
2	Marley (Dance floor)	100cm (W) × 2000cm (L)	28	*Reversible. *Choice of Black/White *With 4 trailers
3	Black board	120cm x 240cm	15	
4	Aluminum Bottom Pipe	3m	30	Silver / Light
		2m	2	
		1m	2	
5	Aluminum Bottom Pipe protect kit (male)		15	
6	Aluminum Bottom Pipe protect kit (female)		15	
7	Black Bottom Pipe	3m	30	8.2kg/piece
		1m	10	3.2 kg/piece
8	Track and Accessories			
	Channel	3m	4	
		2m	4	
		1m	2	
	Hand Live	60m	1	
	Single Carrier		60	
	Master Carrier		2	
	Dead End Pulley		2	
	Live End Pulley		1	
	End Stop		4	
	Adjustable Floor Pulley		1	
	Joint		16	
	Spileing Clamp set (Spileing Clamp*2 Pipe Clamp *2 Clinch bolt set*3)		8	
	Center Pipe Supports set (Pipe Clamp*2 Hanging Clamp*2 Clinch bolt set*3)		22	

Lighting Specifications

Lighting Systems

1. Network system

- Signal transmission method: transfer to DMX system by sACN communication protocol
- In-wall wiring specification CAT.6 type
- Domain CLASS B type, can use domain segment **10.0.10.51~100**
- Can provide mobile NET→DMX signal converter

2. Dimmer and Voltage specification

- Brand/Type : Strand Lighting / EC21
- Voltage: 380V/220V
- 3kw SCR dimming module Max Loading Amp of a single loop: 16A
- 3kw relay module Max Loading Amp of a single loop: 16A
- 5kw SCR dimming module Max Loading Amp of a single loop: 25A
- Signal types that can be received by the signal input terminal: SHOWNET/DMX512

3. Additional Power Supply

- Location: Down stage left Proscenium wall
- Total current load: 400A
- Voltage 3 ϕ 4 wires +G 380V/220V
- [63A CEE Connector](#):
3 ϕ 4+G Total Load 75A X2
- US standard quick connector:
3 ϕ 4+G total load 400A

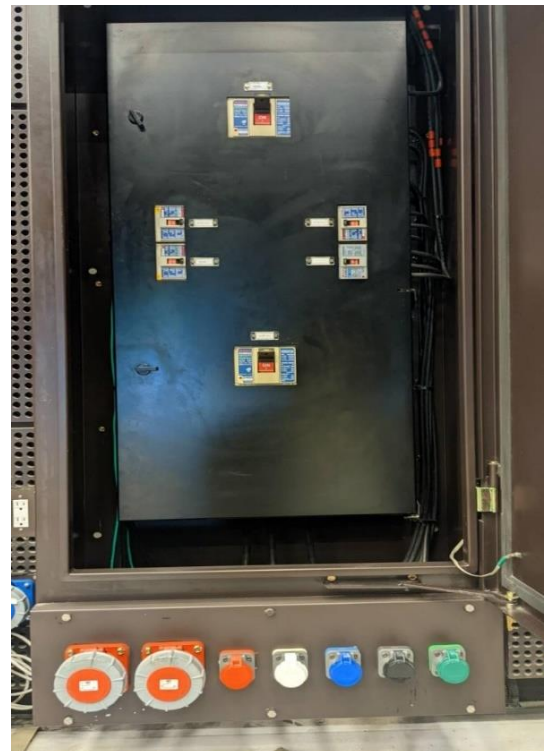

Lighting Equipment List

1. Equipment List

NO.	Item&Type	Total	Location	Amount	Note
1.	Lighting console grandMA 2 full-size	1	Control room		
2.	Lighting console grandMA 3 full-size	1	Control room		
3.	Backup / Playback controller grand-MA 2 Replay Unit	1	Control room		
4.	3KW 6 Circuits Spring Cable Reels Conductix Wampfler SR40.3PA.13GB090+2(2UC)	24	Grid		* speed limit 20cm/sec * No movement during performance
5.	5KW 4 Circuits Spring Cable Reels Conductix Wampfler SR60.3PA.9GD090+2(2UC)	4	Grid		* speed limit 20cm/sec * No movement during performance
6.	Ellipsoidal reflector spotlight 5° ETC Source Four 5°	24	#2 Catwalk	6	
			#3 Catwalk	18	
7.	LED Profile ETC Source Four LED Series 3 5°				Under Preparation
8.	Ellipsoidal reflector spotlight 10° ETC Source Four 10°	56	#2 Catwalk	36	
			#3 Catwalk	20	
9.	LED Profile ETC Source Four LED Series 3 10°				Under Preparation
10.	Ellipsoidal reflector spotlight 14° Selecon SPX 14°	78	#1 Catwalk	78	
11.	Ellipsoidal reflector spotlight 19° Selecon SPX 19°	50	Bridge	6	
			Side Stage	44	
12.	Ellipsoidal reflector spotlight 26° Selecon SPX 26°	218	L/R Ladder	40	
			Bridge	16	
			Side light tower	36	
			L/R Slot	24	
			Side stage	102	

13.	Ellipsoidal reflector spotlight 36° Selecon SPX 36°	132	Ladder	20	
			Sidelight tower	12	
			Side stage	100	
14.	Ellipsoidal reflector spotlight zoom 18-34° Selecon Acclaim Zoomspot MKII 18~34°	8	Side stage	8	
15.	Ellipsoidal reflector spotlight zoom 24-44° Selecon Axial MarkII Zoomspot 24~44°	16	L/R Box	16	
16.	parabolic aluminized reflector light PAR64 KUPO PAR-64LB-UL	48	Lighting Trailer	VN *12	
				N *12	
				M*12	
				W *12	
17.	LED PAR Clay Paky Mini-B ParLED Aqua	48	Side stage		
18.	Fresnel 2 kw Selecon Arena Theatre Fresnel 2 kw	60	Side stage		Barndoor*20
19.	Fresnel 5 kw ARRI ST5 Fresnel 5kw	12	Storage room		*Subject to availability The equipments are shared among 3 venues
20.	LED Pixel Wash ROBE Spiider	14	Side Stage		
21.	Asymmetrical reflector 4-Way square Cyc (1 kw X 4) Selecon Aurora 4-way square	20	Work light	2	Side stage work light
			Side stage	18	
22.	Asymmetrical reflector 4-Way batten Groundrow (1 kw X 4) Selecon Aurora 10AUGRD4	10	Side stage		
23.	Followspot 2.5 kw Lycian M2 Long Lens 2500W	3	Follow Room		
24.	LED Cyc Chauvet Ovation CYC 1 FC	24	Side Stage		

25.	Fog Machine Fazer Antari F-4 (With DMX Fan)	2	Store Room	chargeable items
26.	Hazer Antari HZ-1000 (With DMX Fan)	2	Store Room	chargeable items
27.	Hazer Antari HZ-500 (With DMX Fan)	4	Store Room	chargeable items *Subject to availability

2.Side light Tower

Type : Truss (stackable)

Dimension : (L)60cm × (W) 50cm × (H)230cm

Base Dimension : (L)70cm × (W)60cm

Base weight : 100kg

Amount : 12

Selecon SPX 26 °
Heighg from floor : + 218cm
(include wheel ≐ 12cm)

Selecon SPX 26 °
Heighg from floor : + 161cm
(include wheel ≐ 12cm)

Selecon SPX 26 °
Heighg from floor : + 106cm
(include wheel ≐ 12cm)

Selecon SPX 36 °
Heighg from floor : + 51cm
(include wheel ≐ 12cm)

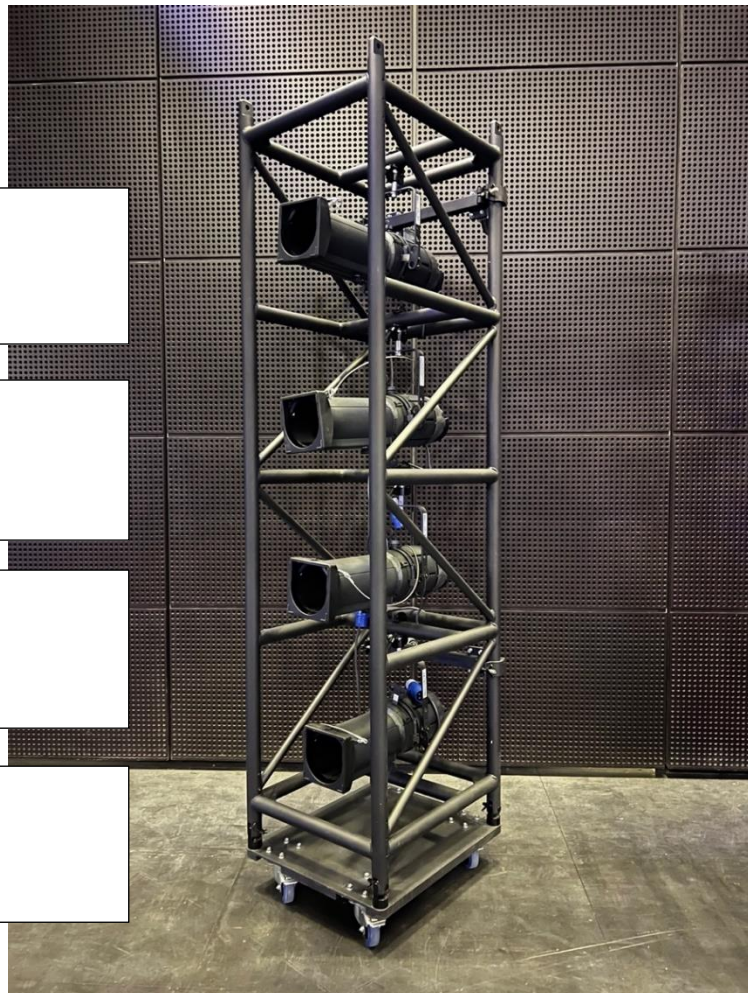

Specified clamp is required for additional lamp:
KUPO 2" SLIM HANDCUFF COUPLER (T Knob)
Type: KCP-828B-T
We provide 12 in this venue



3.Ladder

Total 10 Tracked side light ladder, located at both sides wings. 5 mounts on each side.
Moveable along the up and down stage, Please refer to Standard Light Plan

The total weight of each block: 500 kg
Each crossbar weight limit: 100 kg

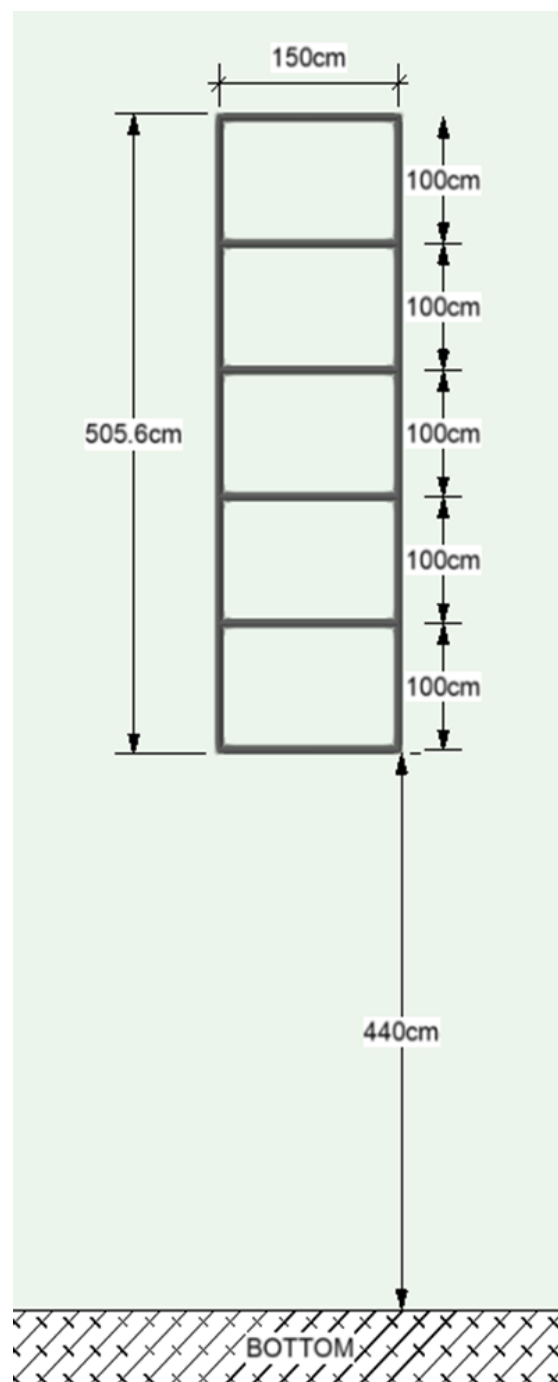

4. Push-around mast lift

Brand/Type : SNORKEL UL40

Max. platform height : 1219 cm

Max. platform Loads Capacity : 136 kg

Lift weight (with battery) : 492kg

Amount: 2

Note : One person only

**Please read and sign the safety instruction
before using the lift**



Lighting Cable and Accessories

Item	Type	Amount	Storage location
GrandMA3 Node	2 Port	7	Cage trailer
DP-81II DMX Splitter	8 Port	6	Cage trailer
Chauvet RDMX Splitter 8	2 to 8 Port	3	Cage trailer
Movable Channel box	3kw / 6 Circuits	24	Side stage
	5kw / 4 Circuits	12	Side stage
Multi-core cable 3kw (With DMX Signal)	2m	20	Grid
	10m	14	Grid
	25m	14	Grid
Multi-core cable 5kw (Harting with DMX Signal)	2m	6	Grid
	10m	6	Grid
	25m	6	Grid
CEE 16A Ex-Cable	1m	60	Cable trailer
	3m	30	Cable trailer
	5m	53	Cable trailer
	10m	54	Cable trailer
	15m	32	Cable trailer
	20m	18	Cable trailer

CEE 32A Ex-Cable	10m	10	Cable trailer
	20m	18 (9/9)	L/R Gallery
19PIN (male)→ 6 circuits CEE16A (female)	1m	54	Cable trailer
19PIN (female)→ 6 circuits CEE16A (male)	1m	10	Grid
		9	Cable trailer
CEE 16A Y-cord	1m	50	Cable trailer
Multi-core cable (19 PIN/2.5mm ²)	5m	20	Cable trailer
	10m	20	Cage trailer
		10	6F Gallery
	20m	20	Cage trailer
		10	6F Gallery
DMX 5PIN cable	1m	14	Cage trailer
	3m	20	Cage trailer
	5m	20	Cage trailer
	10m	20	Cage trailer
	20m	10	Cage trailer
	30m	10	Cage trailer
	10m	10	Grid
	15m	10	Grid
Chauvet Ovation CYC 1 FC	CEE 16A power cord	10	Cage trailer
	Power linking cable(2m)	30	Cage trailer
Colour Frame & Fixture Accessories			
Selecon SPX Colour Frame 6"	15.8*15.8cm	478	Lighting cabinet
Selecon SPX Colour Frame 4"	12.5*12.5cm	40	Lighting cabinet
Selecon SPX IRIS		40	Lighting cabinet
Selecon SPX GOBO Holder	B SIZE	60	Lighting cabinet
ETC SourceFour IRIS		12	Lighting cabinet
ETC SourceFour 5° Colour Frame 12"	35.5*35.5cm	24	Lighting cabinet
ETC SourceFour 10° Colour Frame	30.5*30.5cm	70	Lighting cabinet
Selecon Arena Fresnel 2 kw Colour Frame	24.5*24.5cm	60	Lighting cabinet
ARRI ST5 FRESNEL 5KW Colour Frame	Ø40.5cm (circle)	12	Stroage Room
PAR-64 Colour Frame 8"	25.5*25.5cm	48	Lighting cabinet

Cyc Selecon Aurora 4-way square	30.5*31cm	120	Lighting cabinet
Top Hat	Full Top Hat	40	Cage trailer
Other Accessories			
BOOM BASE		6	Side Stage
BOOM	180 cm	6	Side Stage
Backlite Base Stand (with adapter)	(H)13cm	30	

*Backlite Base Stand



Dimmer circuits layout chart

1. Stage Floor circuits layout chart (*red frame are unconfigured Module)

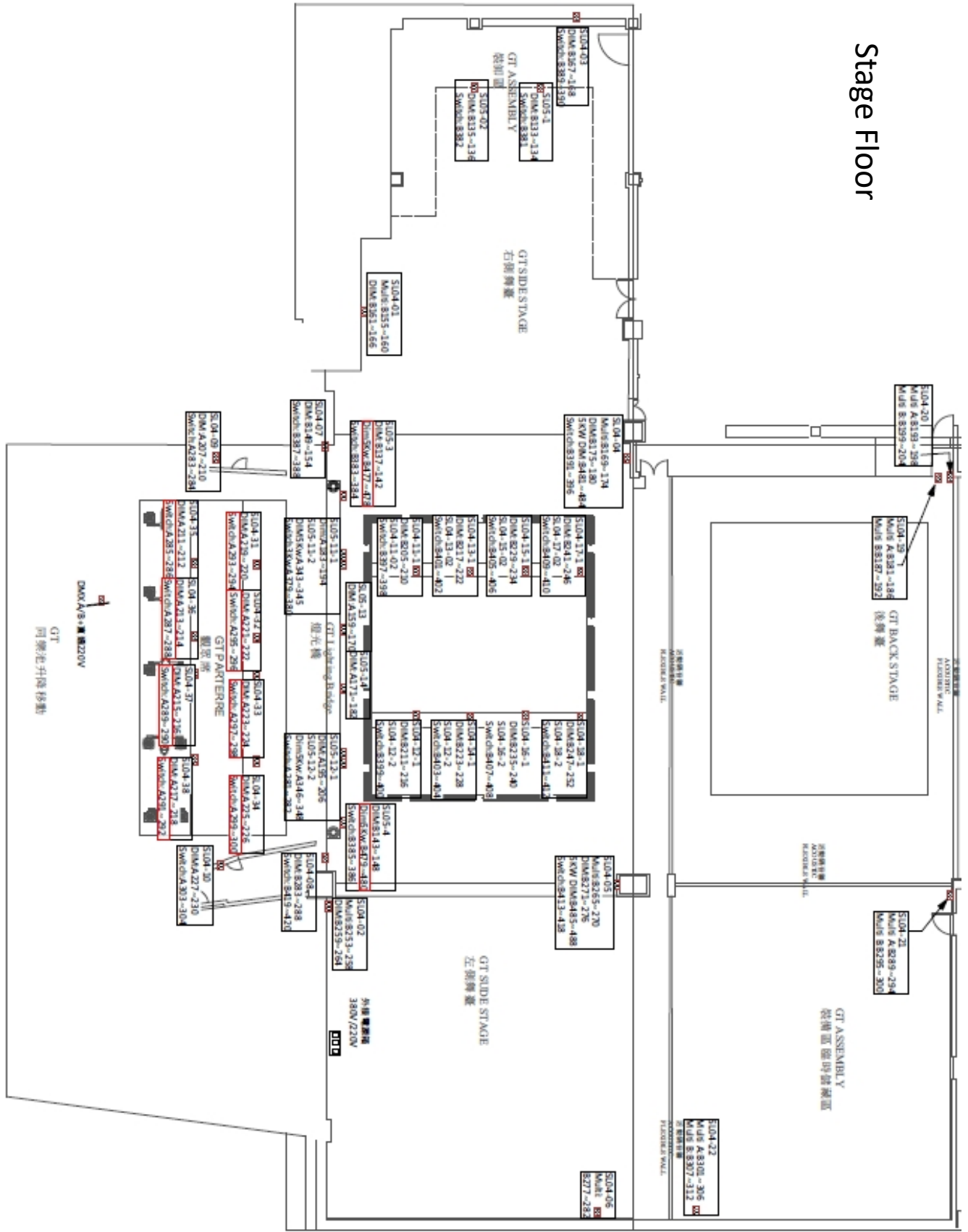

2. 6F&7F layout chart (*red frame are unconfigured Module)

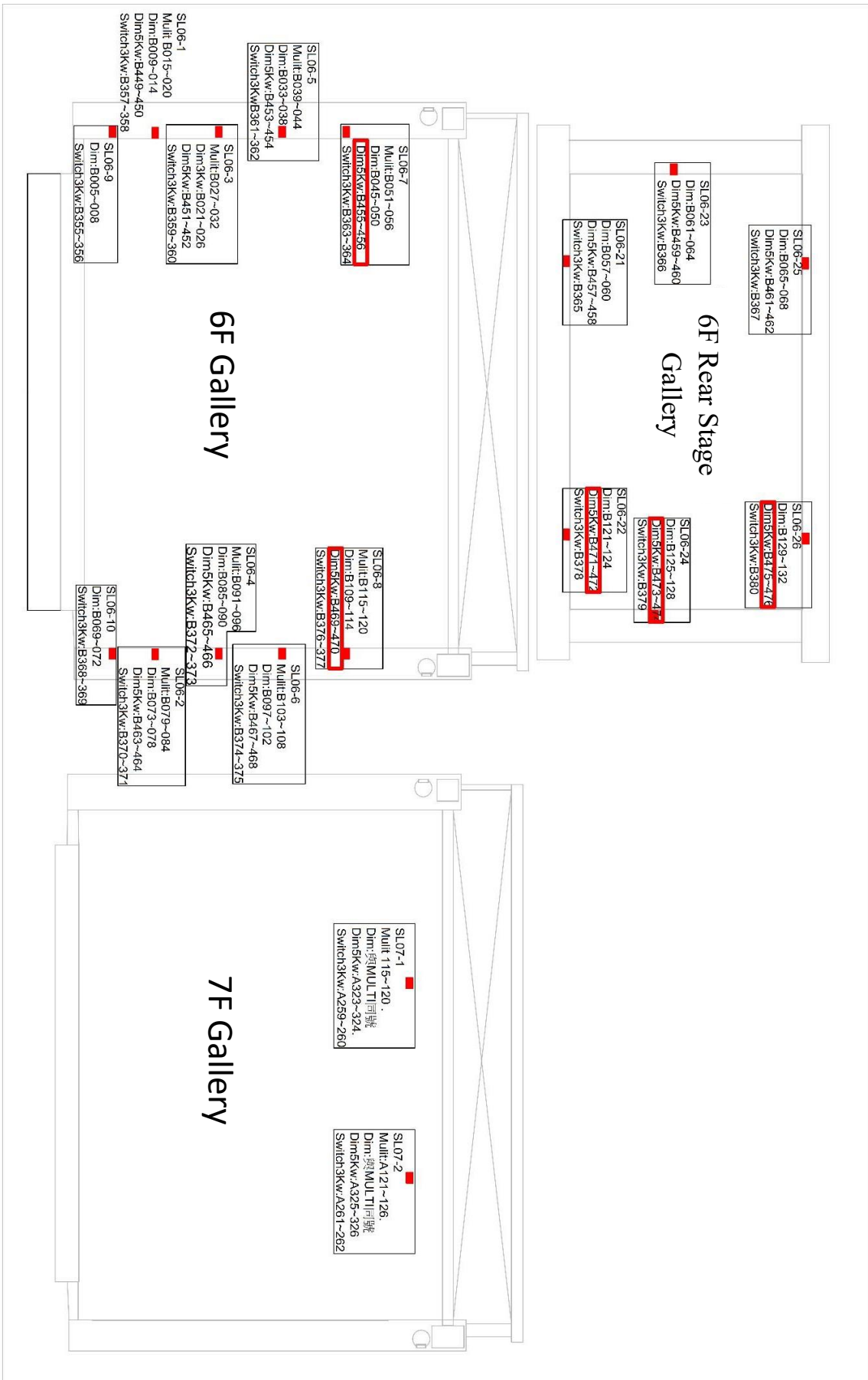

3. 10F circuits layout chart

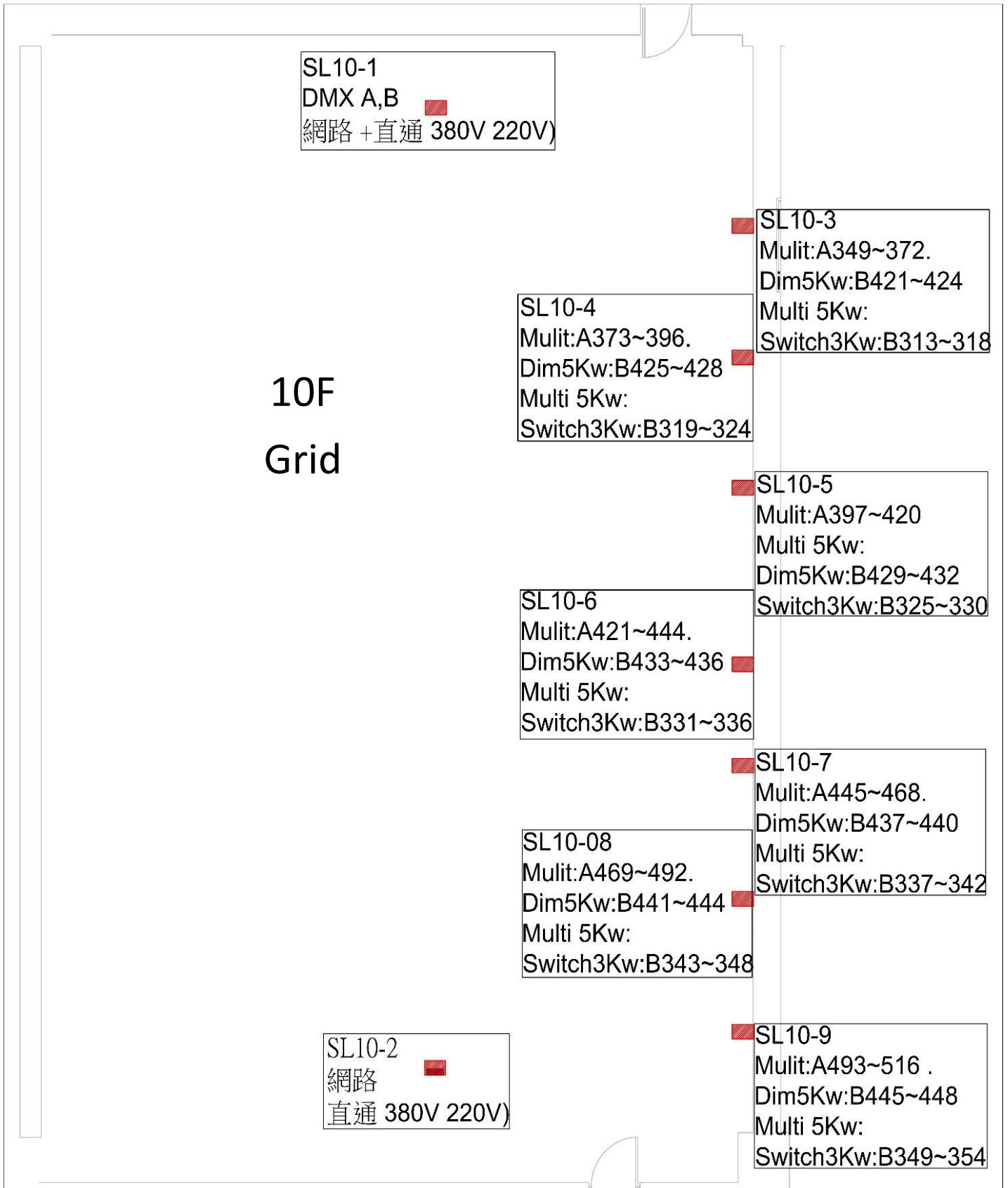

4. 7F Catwalk & Lighting Box circuits layout chart

7F Catwalk & Box

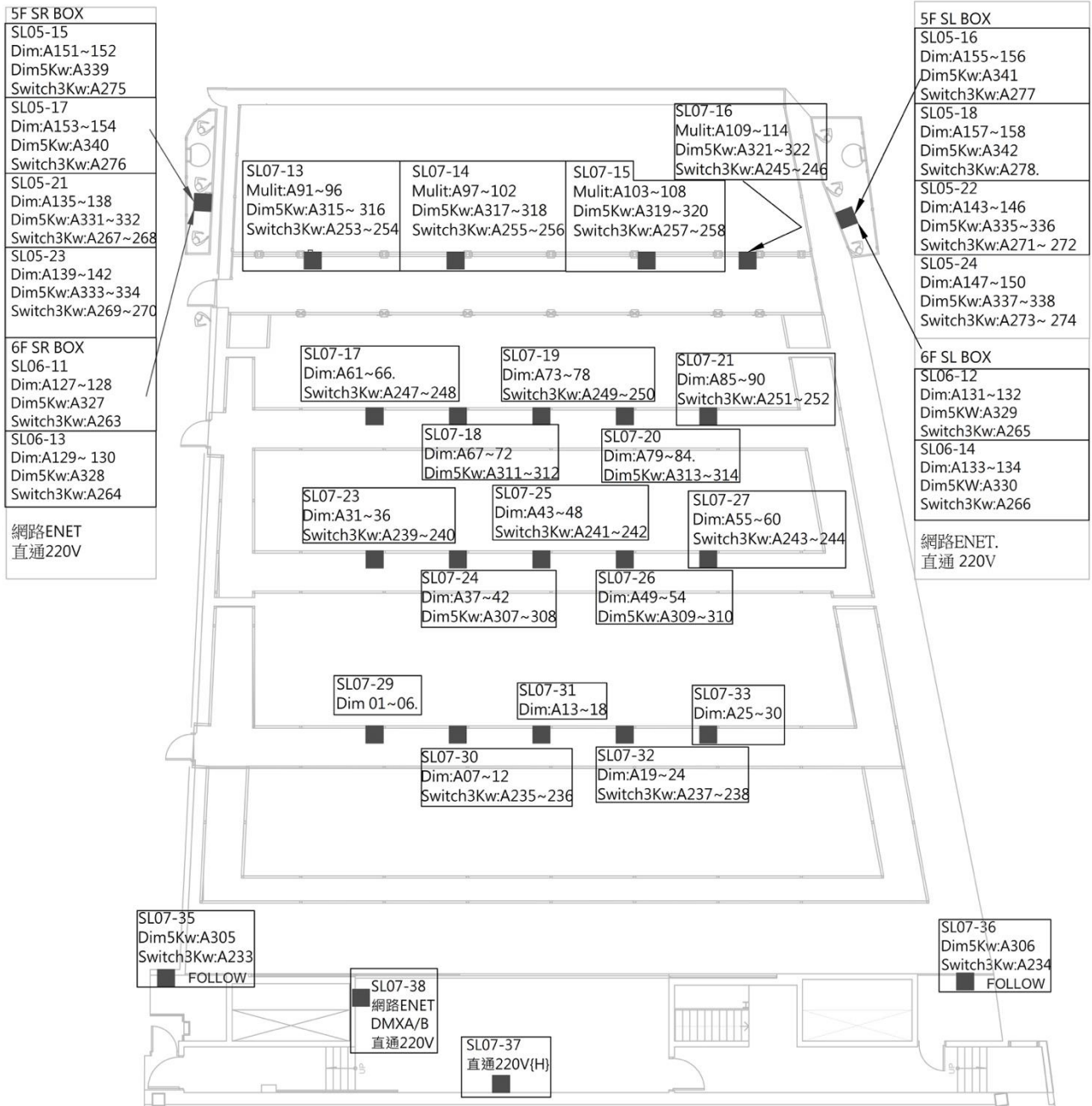

House Light

MK2 NODE--IP:10.0.10.14

Universe : 20 sACN

Auditorium

Ceiling Lamp : ※ Please “Park” the Circuits channel to full

Circuit : 17 (Above Fore-Orchestra Pit) Control DIM : 40

Circuit : 25 (Below the #2 catwalk) Control DIM : 39

Circuit : 23 (Below the #3 catwalk) Control DIM : 38

Circuit : 11 (Near the Control Room) Control DIM : 37

Recessed Downlight

DIM : 9 (Row 24 ~ 26)

DIM : 10 (Row 22 ~ 23)

Wall Washer

Up Stage Right DIM : 15 Down Stage Right DIM : 29 (Near the SR-Box)

Up Stage Left DIM : 16 Down Stage Left DIM : 30 (Near the SL-Box)

SL VIP Balcony

DIM : 21 (Recessed DownLight)

DIM : 28 (Wall Washer)

SR Think Tank

DIM : 22 (Recessed DownLight) / 27 VIP Box

Stair Light

DIM : 7 (ALL)

Standard Light Plan

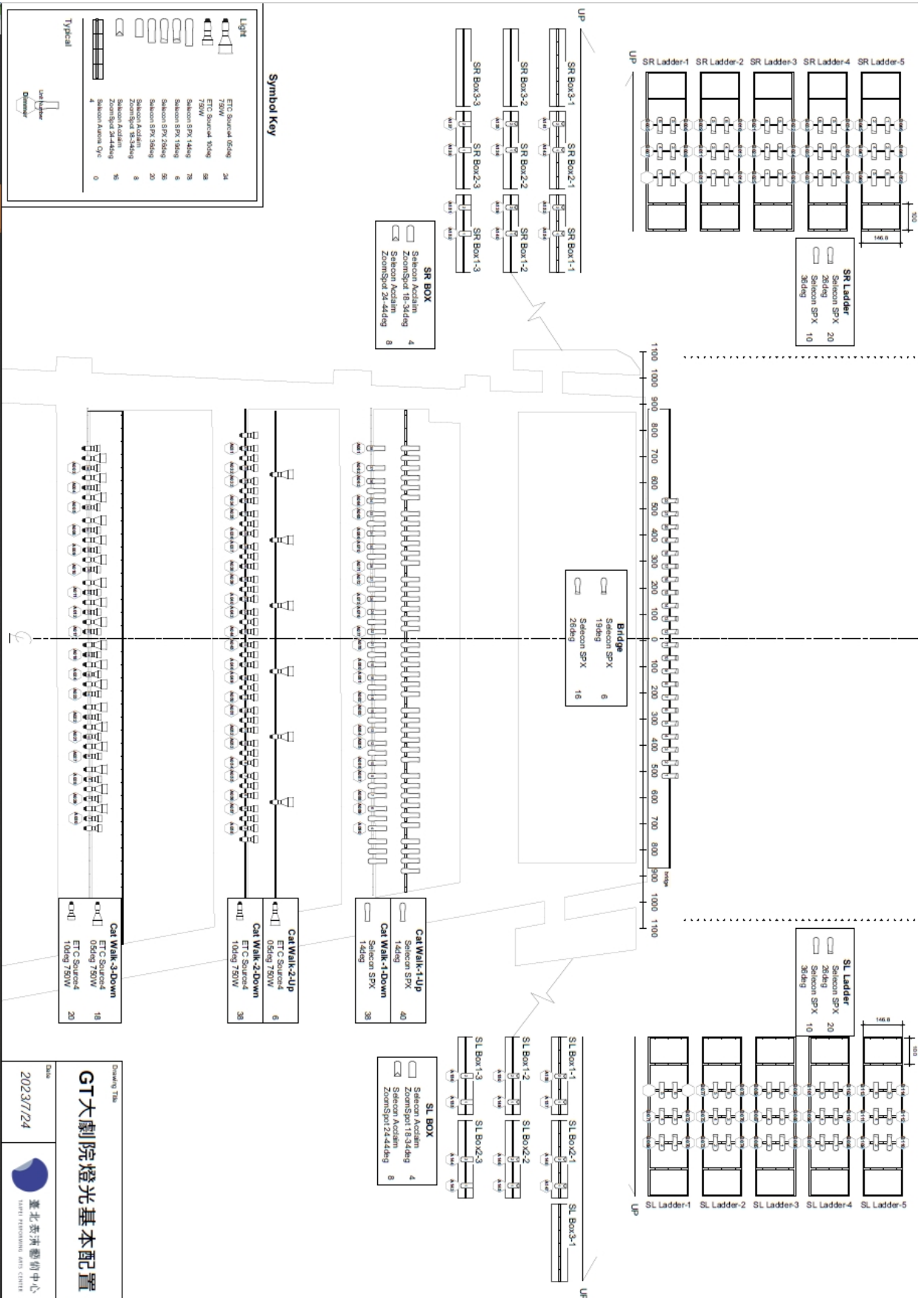

Drawing Title

GT大劇院燈光基本配置

Date

2023/7/24

臺北表演藝術中心
TAIPEI PERFORMANCE ARTS CENTER

Audio Specification

Audio Control Room

Audio Control Room				
NO.	Item	Type	Amount	Note
1	Digital Audio Mixer	MIDAS HD-96	1	Main system
2	I/O System	MIDAS DL-153	1	Main system
3	Digital Audio Mixer	MIDAS HD-96	1	Backup system
4	I/O System	MIDAS DL-153	1	Backup system
5.	Solid State Recorder	Tascam SS-R250N	2	
6.	Nearfield Monitor Speaker	Dynaudio BM12-A	2	
7.	CD/USB Player	NUMARK MP103USB	1	
8.	Microphone Splitter	Behringer MS-8000	2	

Loudspeaker System

Loudspeaker System				
NO.	Item	Type	Amount	Note
1	FOH-L	K&F Sequenza 10N	9	Horizontal 77° (W x H x D)795 x 303 x 491 mm Weight : 34 kg
2	FOH-Center	K&F Sequenza 10N	6	Horizontal 77° (W x H x D)795 x 303 x 491 mm Weight : 34 kg
3	FOH-R	K&F Sequenza 10N	9	Horizontal 77° (W x H x D)795 x 303 x 491 mm Weight : 34 kg
4	SUB-L	K&F Sequenza 10B	3	2*15" omni (W x H x D)807 x 470 x 991 mm Weight : 62 kg
5	SUB-R	K&F Sequenza 10B	3	2*15" omni (W x H x D)807 x 470 x 991 mm Weight : 62 kg
6	STALL-L	K&F CA-1215-9	2	90° x 50° (W x H x D)434 x 680 x 412 mm Weight : 36.4 kg
7	STALL-R	K&F CA-1215-9	2	90° x 50° (W x H x D)434 x 680 x 412 mm Weight : 36.4 kg
8	STALL-L SUB	K&F Sequenza 10B	1	2*15" omni (W x H x D)807 x 470 x 991 mm Weight : 62 kg
9	STALL-R SUB	K&F Sequenza 10B	1	2*15" omni (W x H x D)807 x 470 x 991 mm Weight : 62 kg
10	Balcony Delay	K&F CA-106	7	90° x 60° (W x H x D) 195 x 365 x 206.5 mm Weight 6.7 kg
11	7F Delay	K&F Gravis 12N	8	65° x 50° (W x H x D)350 x 596 x 318 mm

Stage Monitor System

Stage Monitor System				
NO.	Item	Type	Amount	Note
1	SR Ladder (Flexible)	K&F Gravis 12N	3	65° x 50° (W x H x D) 350 x 596 x 318 mm Weight: 17.8 kg
2	SL Ladder (Flexible)	K&F Gravis 12N	3	65° x 50° (W x H x D) 350 x 596 x 318 mm Weight: 17.8 kg
3	Stage Monitor (Flexible)	K&F CA-1215-9	8	90° x 50° (W x H x D) 434 x 680 x 412 mm Weight: 36.4 kg chargeable items
4	Power Amplifier	UNIKA PWM-10000Q 4ch	2	chargeable items

Microphone

Microphone				
NO.	Item	Type	Amount	Note
1	Wireless Microphone Receiver	MIPRO ACT-747	1	
2	Wireless Handheld Microphone	MIPRO ACT-7H	4	
3	Microphone	SHURE SM-58	6	chargeable items
4	Boundary Microphone	SHURE MX392/C	8	chargeable items
5.	Condenser Microphone	DPA-4011A	8	chargeable items

Intercom & backstage communication system

Intercom & backstage communication system				
NO.	Item	Type	Amount	Note
1	Beltpack	Clear-Com HBP-2X	16	
2	(Single-ear) headsets	Clear-Com CC-300	16	
3	Wireless Beltpack (With headsets)	Clear-Com FS II-BP19-X4-EU + CC-300	6	chargeable items

Video equipment

Video equipment				
NO	Item	Type	Amount	Note
1	CCTV (For Conductor)	CDOUBLES TWA-CE2425N4.2X	2	chargeable items
2	32" Mobile LED LCD	SAMSUNG UA32N4000AWZW	4	chargeable items
3	42" Mobile LED LCD	SAMSUNG UA43TU8000WXZW	3	*One is fixed on the 6F auditorium wall chargeable items

Cable & Audio Accessories

Cable & Stand Accessories				
NO	Item	Type	Amount	Note
1	Orchestra music stand	K&M 11965-000-55-black	60	
2	Music stand light	K&M 12295-018-55-black	65	
3	Instrument Tray	K&M 12218-000-55-black	60	
4	Orchestra conductor stand desk	K&M 12338-000-55-black	2	
5	Mic Stand	CNBear K308B	16	
6	Microphone Stand (two-boom)	K&M 25200-300-55	10	Please bring your own 3/8 to 5/8 thread adapter
7	Microphone stand (Low-level)	K&M 25900-300-55	10	Please bring your own 3/8 to 5/8 thread adapter
8	Microphone stand (Round Base)	K&M 26145-300-55	10	Please bring your own 3/8 to 5/8 thread adapter
9	Microphone stand (Low/Round Base)	K&M 25960-300-55	10	Please bring your own 3/8 to 5/8 thread adapter
10	Speaker Stand	SoundKing SB315	8	
11	Speaker Stand	ST168B	8	
12	Microphone XLR Cable	5M	10	
13	Microphone XLR Cable	10M	10	
14	Microphone XLR Cable	20M	10	
15	4P-Speakon	5M	5	
16	4P-Speakon	10M	5	
17	4P-Speakon	20M	10	
18	3mm/3C Power Cord 5M	5M	5	
19	3mm/3C Power Cord 15M	15M	5	
20	Power Strip		5	

Speaker System Dispose Chart

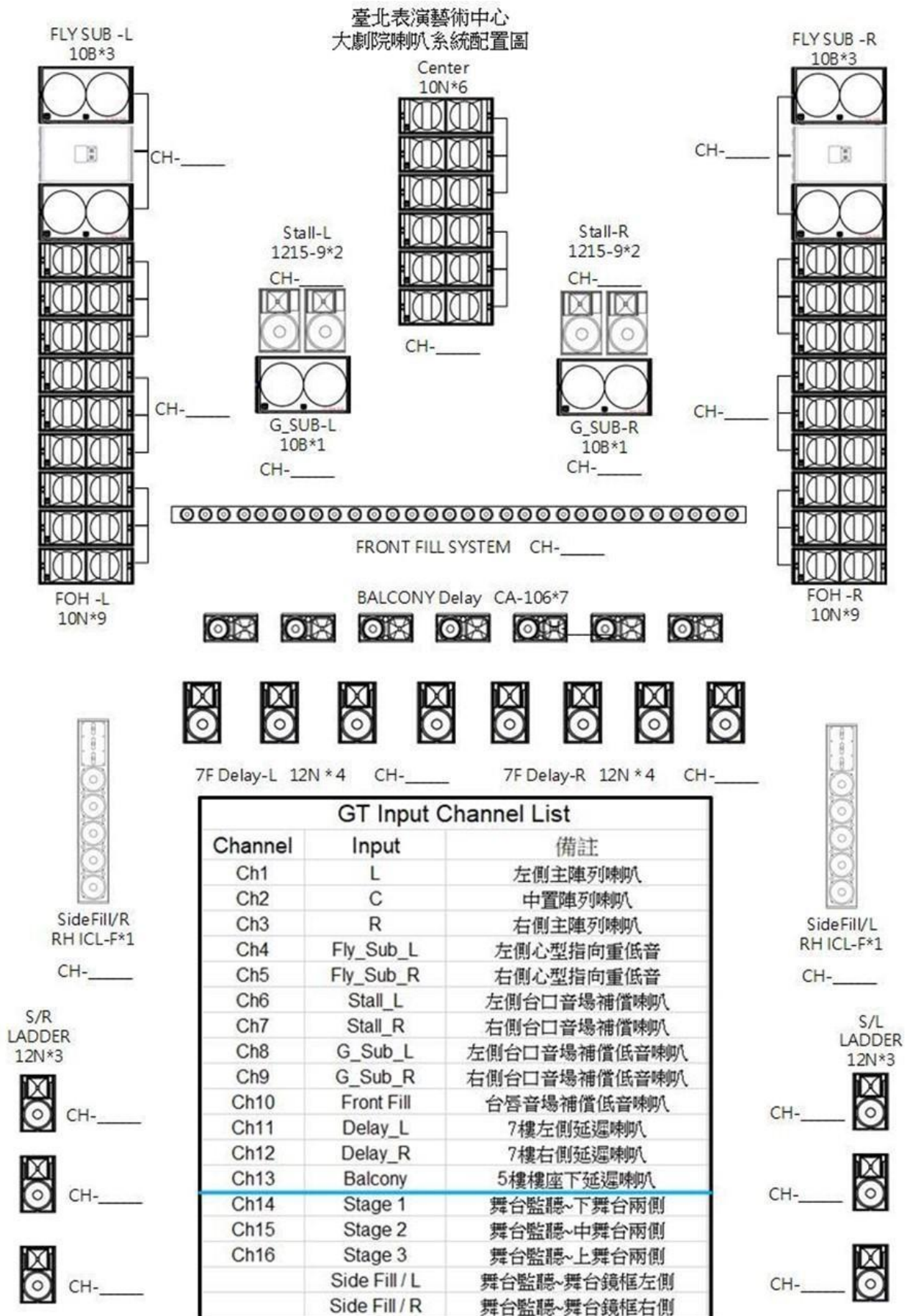

Channel Dispose Chart

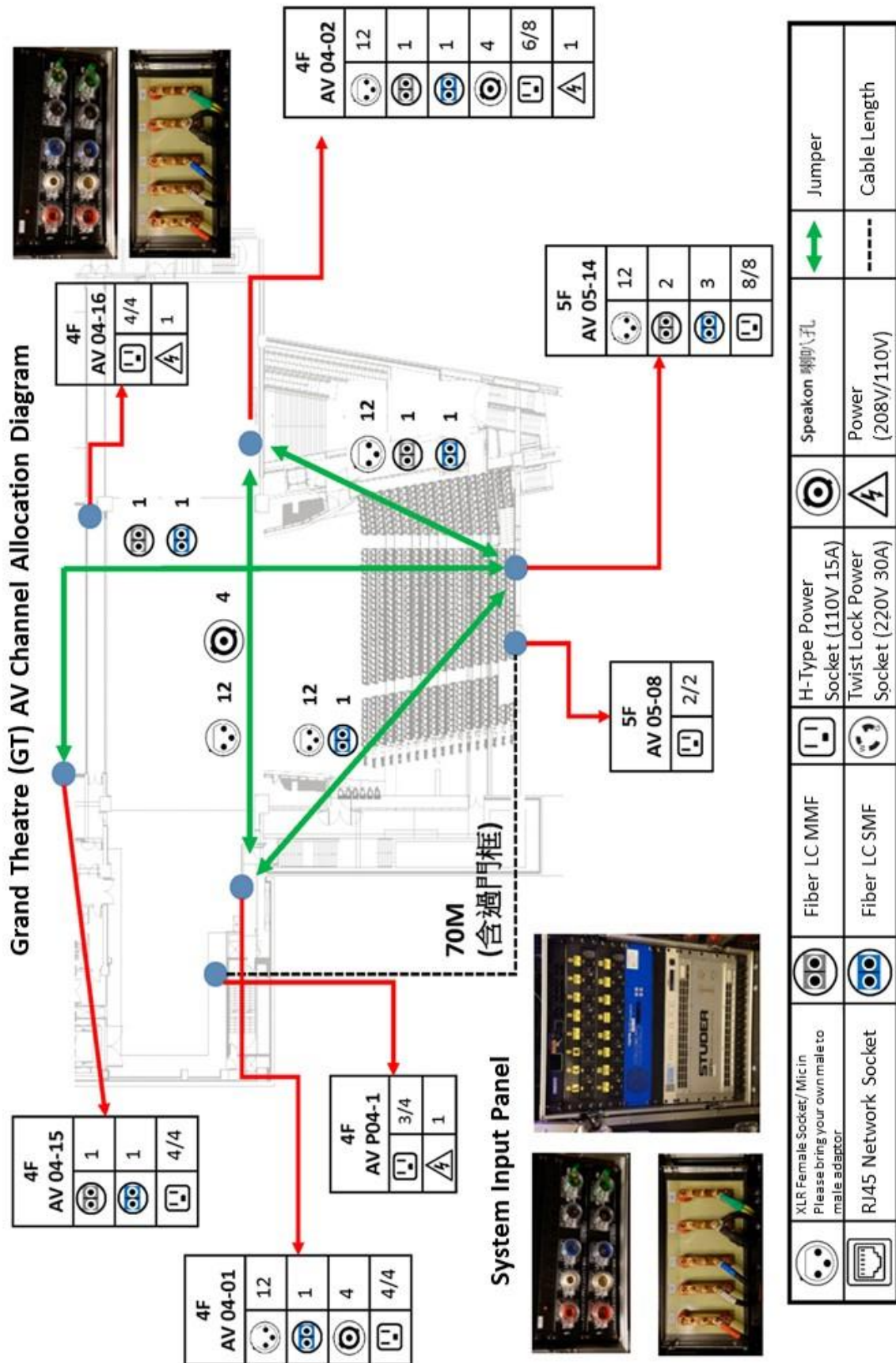

Panel Layout

GT Panel Layout



Mic in

Control Panel		Down Stage Right		Down Stage Left	
Panel	NO.	Panel	NO.	Panel	NO.
AV 05-14	1-12	AV 04-01	1-12	AV 04-02	1-12



Speakon

Control Panel		Down Stage Right		Down Stage Left	
Panel	NO.	Panel	NO.	Panel	NO.
		AV 04-01	1-4	AV 04-02	1-4



SMF

Control Panel		Down Stage Right		Down Stage Left	
Panel	NO.	Panel	NO.	Panel	NO.
05-14	1	04-01	1		
05-14	2			04-02	1
Control Panel		Up Stage Right			
05-14	3	04-15	1		



MMF

Control Panel		Down Stage Right		Down Stage Left	
Panel	NO.	Panel	NO.	Panel	NO.
05-14	2			04-02	1
Control Panel		Up Stage Right			
05-14	3	04-15	1		

Other Equipments & Dressing Room

Other Equipments

No.	Item	Dimension	Amount	Note
1	Aluminum Stage Deck	178cm*95cm	4	*With two-dimensional legs suitable for front and rear rows
2	Back Side Chair (Black)		80	
3	Folding table	180cm*75cm	28	
4	Steamers		2	
5	Iron + sleeve board		1 set	
6	Dressing Mirror		2	
7	Hanger Cart		8	1 is used for cleaning equipments storage
8	Hanger		100	

List of Dressing room

Room No.	Room Name	Capacity	Toilet	Shower	Note
3F (Total : 12 / Capacity : 59)					
301	(GT) Personal	1	1	1	
302	(GT) Personal	1	1	1	
303	(GT) Group (Medium)	5	1	1	
304	(GT) Group (Medium)	5	1	1	
305	(GT) Personal	1	1	1	
306	(GT) Personal	1	1	1	
307	(GT) Personal	1	1	1	
308	(GT) Group (Large)	16	none	none	
309	(GT) Personal	1	1*	1	Accessible toilet
310	(GT) Personal	1	1*	1	Accessible toilet
311	(GT) Group (Large)	14	none	none	
312	(GT) Group (Large)	12	none	none	

4F (Total : 2 / Capacity : 3) (Subject to availability)					
401	(BB) Personal	2	1*	1	Accessible toilet
402	(BB) Personal	1	none	none	
5F(Total : 6 / Capacity : 21) (Subject to availability)					
501	(BB) Personal	1	1	1	
502	(BB) Personal	1	1	1	
503	(BB) Group (Medium)	5	1	1	
504	(BB) Group (Medium)	5	1	1	Shower without Cubicle
505	(BB) Personal	1	1	1	
506	(BB) Group (Medium)	8	none	none	
6F (Total : 9 / Capacity : 74) (Subject to availability)					
601	(GP) Group (Medium)	9	none	none	
602	(GP) Group (Medium)	5	none	none	
603	(GP) Group (Medium)	4	none	none	
604	(GP) Group (Large)	17	1	3	
605	(GP) Group (Large)	19	1	3	
606	(GP) Group (Medium)	5	1	1	
607	(GP) Group (Medium)	5	1*	1	Accessible toilet
608	(GP) Group (Medium)	6	none	none	Near Orchestra Pit wash basin *1
609	(GP) Group (Medium)	4	none	none	Near Orchestra Pit wash basin *1
7F (Total : 6 / Capacity : 21) (Subject to availability)					
701	(GP) Personal	1	1	1	
702	(GP) Personal	1	1	1	
703	(GP) Group (Medium)	5	1	1	
704	(GP) Group (Medium)	5	1	1	
705	(GP) Personal	1	1	1	
706	(GP) Group (Medium)	8	none	none	
8F (Total : 1/ Capacity : 6) (Subject to availability)					
	Spare Dressing Room	6	1	1	Not available currently